

BLÜCHER Channel® linear drainage

Installation Guide

■ Pre installation

BLÜCHER Channel® linear drainage channels may be installed into pre-formed recesses or cast directly into the floor structure.

Pre-formed recesses should generally be 100 mm wider and 50 mm deeper (minimum) than the channel dimensions (please note that if additional concrete anchor tangs are to be fitted, the width of the recess is to be increased correspondingly).

It is important that the entire channel is supported by concrete without any voids, and if required also the back of the channel edge can be filled with concrete, back-filling is to be carried out prior to installation (fig. 1). The channel can also be ordered with this edge infill pre installed.

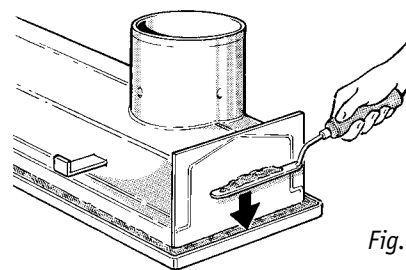

Fig. 1

■ Assembly

Channels more than 6 metres long consist of two or more channel sections to be jointed with flanges on site. Each channel section is marked with channel type no. and numbered consecutively.

Custom-made channels with several flanged joints are accompanied by a drawing with unique flange reference numbers for each joint. The unique flange reference numbers as indicated on the drawing are marked on each end of every channel section.

To assemble the consecutive channel sections place the sealing supplied with the channel between the flanged joints prior to bolting together with the stainless steel nuts and bolts provided - nuts to be tightened to 17 Nm.

After assembly, cut away any parts of the sealing pressed into the channel.

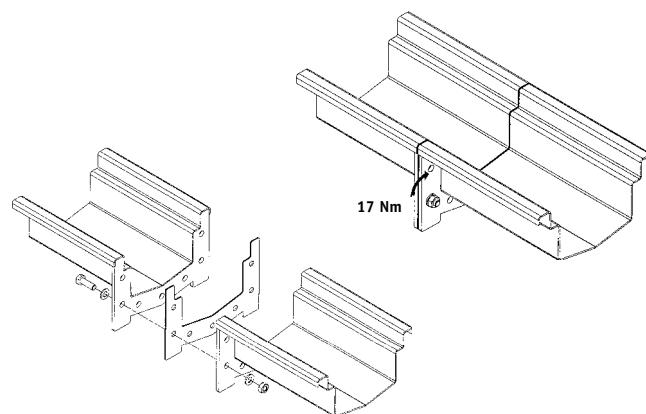

Fig. 2

■ Levelling

On channels with anchor tangs (fig. 2), these must be pulled out square. Channels with stabilizing angle can be fitted with additional anchor tangs type no. 670.000.002 (fig. 3).

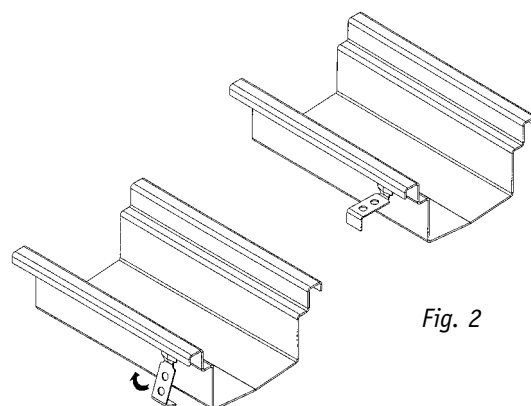
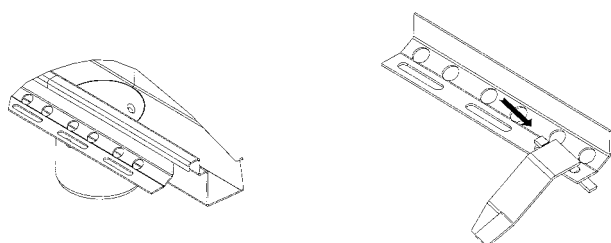
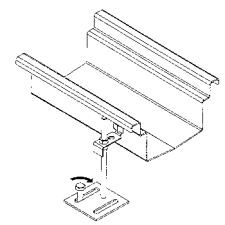
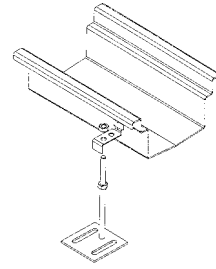

Fig. 3



Set the channel with the top edge level with the finished floor. BLÜCHER's levelling feet type no. 670.000.001 are suitable for this. Fix the levelling feet to the anchor tangs/stabilizer angle of the channel with two nuts. In addition, we recommend to fix the levelling feet to the base to prevent flotation.

Ensure the channel is not twisted before backfilling, and it is also recommended to water test the installation before finally backfilling.



Mounting of levelling feet in anchor tangs

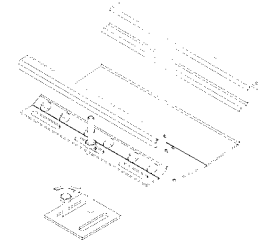
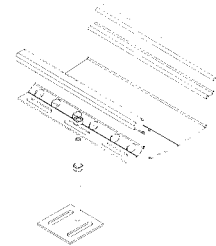

Mounting of levelling feet in stabilizer angle

■ Backfilling

Backfill the recess with good quality free flowing concrete/grout, ensuring good compaction to prevent any voids being formed under the channel edges. During backfilling ensure that the channel does not move. It is advisable to weigh down the channel to prevent flotation. Any concrete spilled on the channel should be cleaned off as soon as possible.

■ Fitting gratings

It is advisable to install gratings after the channel is in position to avoid concrete stains on the gratings.

Channel grates are supplied in standard 500 mm or 1000 mm long sections and are designed to fit between the cross bars welded into the channel. Any gratings produced to a special length are supplied pre-installed. When a special length grating is removed, e.g. during backfilling, it must be re-positioned in its correct location.

■ Cleaning

After installation is complete, the channel system should be cleaned out checking that filter baskets, water traps and outlets are free from blockage.

Concrete stains etc. should be removed with soapy water and a stiff nylon brush.

Please note: Wire brushes and metal scrapers will contaminate the stainless steel and should not be used.

■ Protection

Channel edges and gratings should be protected from damage during the completion of building works (if applicable).

For further information:

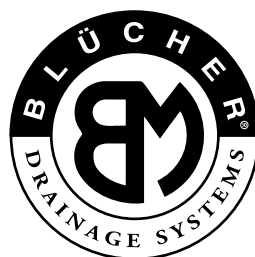

BLÜCHER UK Ltd · Station Road Estate · Tadcaster
North Yorkshire · LS24 9SG
Tel. +44 (0)1937 838000 · Fax +44 (0)1937 832454
mail@bmstainless.co.uk · www.bmstainless.co.uk